



OPS



NSWT



NSWTS

OPS	NSWT			NSWTS
材質	材質	硬度	處理	材質
黃銅(C360C)	SCM435	-	染黑處理	不銹鋼

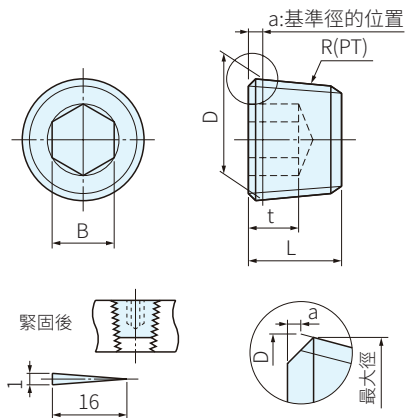
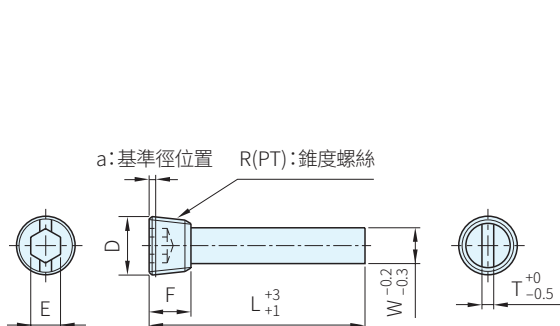

螺牙部 JIS B0203 R(PT)

位置a的基準徑為理論值，有時NO.J · S · 1 實際螺牙最大徑會因端面的倒角而變小

品號		L	D	a	牙 / in	Pitch	F	B	T	R(PT)	單價
TYPE	W										
OPS	8.2	100	9.728	0.45	28	0.91	7	5	2	1/8-28	·
		200									·
	11.2	125	13.157	0.7	19	1.34	8.9	6	2.5	1/4-19	·
		250									·
	14.7	150	16.662	0.9	14	1.81	10	8	3	3/8-19	·
		300									·
	18.2	200	20.955	1.1	11	2.31	12	10	3	1/2-14	·
		400									·
	23.2	300	26.441	1.1	11	2.31	14	14	3	3/4-14	·
		500									·
	26.7	400	33.249	1.1	11	2.31	17	17	3	1-11	·
		600									·

訂貨：品號 [ ] - [ ] 交期： [ ] 天  
OPS 8.2 - 100

品號		D	a	牙/英吋	pitch	L	B	t	R(PT)	庫存		
TYPE	NO.									NSWT	NSWTS	
NSWT	J	7.723	0.45	28	0.91	6	4	-	3.0	1/16-28	·	
	S	7.779	0.47	27	0.94	6.4	4	<sup>+0.03</sup> <sub>-0.032</sub>	3.1	1/16-27	·	
	1	9.728	0.45	28	0.91	7	5	-	3.5	1/8-28	·	·
NSWTS (不銹鋼)	2	13.157	0.7	19	1.34	8.9	6	-	4.5	1/4-19	·	·
	3	16.662				10	8	-	5	3/8-19	·	·
	4	20.955	0.9	14	1.81	12	10	-	6	1/2-14	·	·
	6	26.441				14	14	-	7	3/4-14	·	·
	8	33.249	1.1	11	2.31	17	17	-	9	1-11	·	·

PS. 備註

- NSWTS的S為ANS規格螺牙，安裝時，請用英吋的六角扳手5/32
- NSWTS的J為JIS規格螺牙

訂貨：品號 [ ] 交期： [ ] 天  
NSWTS